

Explosion-Proof Linear Actuators

The EL100 Linear Actuator offers you all the advantages of Exlar's patented inverted roller screw actuator designs in a Class I, Div 1, Groups B, C, D & T3 explosion-proof package. The EL100 linear actuators also meet ATEX essential requirements and are in conformity with the EU ATEX Directive 94/9/EC.

This electro-mechanical actuator series provides engineers a clean, fast, simple and cost effective replacement for hydraulic actuation and a longer life alternative to other mechanical actuation. The roller screw technology manufactured by Exlar outperforms rival ball screws by 15 times in travel life, and can carry higher loads. The compact design allows users to effectively replace hydraulic or pneumatic cylinders with an electromechanical actuator, yet meet all required capabilities of the application. Reduced emissions, reduced energy consumption (80% system energy efficiency), increased position control and accuracy – all leading to reduced cost – are provided by servo electric actuation.

The EL100 actuator is compatible with nearly any resolver based servo amplifier. In addition, Exlar offers the EXP Series of positioners. The EXP Series also offers Class I Division 1 and ATEX conformity.

For more information on motors and actuators for incandive or harsh environments please see Exlar's Process Control Industry Brochure.

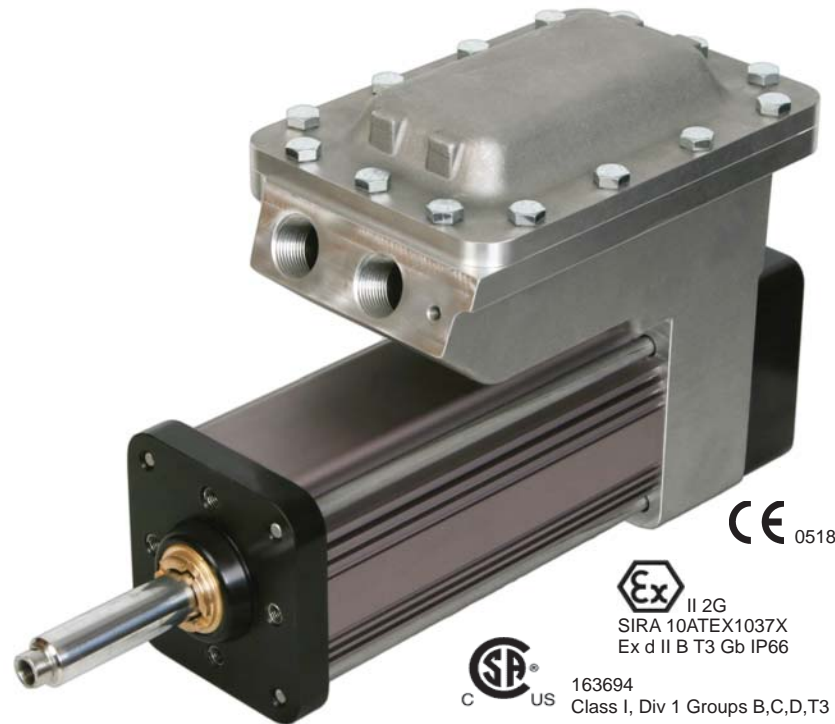

Features

- Speeds to 25 ips
- Forces to 2000 lbs
- 8 pole brushless motors
- 6 inch stroke
- Feedback configurations for nearly any resolver-based servo amplifier and Exlar's EXP Series positioner.
- Several mounting configurations
- 24 VDC to 460 Vrms windings
- Class 180H insulation
- CSA Class I, Div 1 Group B, C, D and T3 explosion-proof rating
- ATEX – Ex d II B T3 Gb IP66
- Completely sealed motor assures trouble-free operation

Applications

For process applications, the EL100 actuator offers a unique combination of high speed, performance and accuracy in a compact package when coupled with Exlar's SV Series or EXP Series positioners.

High performance is achieved with respect to speed, linearity, load sensitivity, deadband and temperature range. For valve and damper control, the EL Series actuators continuously hold the position of the valve stem or shaft allowing extremely fast response to the smallest command signal changes without overshoot even when friction is present. This results in improved loop performance and reduced process variability.

EL Series explosion-proof actuators are well-suited to many applications such as:

- Valve control
- Damper control
- Printing presses
- Engine test stands
- Fuel skids
- Refineries
- Paint booths
- Shipboard fuel management

EL100 MECHANICAL/ELECTRICAL SPECIFICATIONS

Nominal Backlash	in (mm)	0.004 (.10)							
Maximum Backlash (preloaded)	in (mm)	0.0							
Lead Accuracy	in/ft (µm/300 mm)	0.001 (.025)							
Maximum Radial Load	lb (N)	40 (179)							
Environmental Rating	Standard	IP66							
Motor Designation	Stator	2A8-10	2B8-25	2C8-40	218-40	238-40	258-40	268-40	
Ambient Temperature	°C	25°/80°	25°/80°	25°/80°	25°/80°	25°/80°	25°/80°	25°/80°	
RMS Sinusoidal Commutation Data									
Continuous Motor Torque	lbf-in	35.9/24.8	35.9/24.8	36.5/25.2	39.6/27.3	40.0/27.6	39.5/27.3	39.9/27.6	
	(N-m)	4.06/2.80	4.06/2.80	4.12/2.85	4.47/3.09	4.52/3.12	4.46/3.08	4.51/3.11	
Torque Constant @ 25°C (Kt)	lbf-in/A	1.7	1.7	2.6	3.2	6.6	11.6	13.2	
	(N-m)	0.19	0.19	0.30	0.37	0.75	1.31	1.50	
Continuous Current Rating (IG)	A	23.6/16.3	23.6/16.3	15.6/10.7	13.6/9.4	6.8/4.7	3.8/2.6	3.4/2.3	
Peak Current Rating	A	47.1/32.5	47.1/32.5	31.1/21.5	27.3/18.8	13.5/9.3	7.6/5.3	6.7/4.7	
Trapezoidal Commutation Data									
Continuous Motor Torque	lbf-in	34.3/23.7	34.3/23.7	34.9/24.0	37.8/26.1	38.2/26.4	37.7/26.0	38.1/26.3	
	(Nm)	3.88/2.67	3.88/2.67	3.94/2.72	4.27/2.95	4.32/2.98	4.26/2.94	4.31/2.97	
Torque Constant @ 25°C (Kt)	lbf-in/A	1.3	1.3	2.0	2.5	5.2	9.0	10.3	
	(N-m)	0.15	0.15	0.23	0.29	0.58	1.02	1.17	
Continuous Current Rating (IG)	A	28.9/19.9	28.9/19.9	19.1/13.2	16.7/11.5	8.3/5.7	4.7/3.2	4.1/2.8	
Peak Current Rating	A	57.7/39.8	57.7/39.8	38.1/26.3	33.4/23.1	16.5/11.4	9.4/6.5	8.3/5.7	
Motor Stator Data									
Voltage Constant @ 25°C (Ke)	Vrms/Krpm	11.6	11.6	17.9	22.1	45.2	78.9	90.4	
	Vkp/Krpm	16.5	16.5	25.3	31.3	64.0	111.6	127.9	
Pole Configuration		8	8	8	8	8	8	8	
Resistance (L-L)	Ohms	0.10	0.10	0.20	0.30	1.2	3.8	4.86	
Inductance (L-L)	mH	0.79	0.79	1.9	2.93	12.2	37.2	48.9	
Brake Inertia	lbf-in-sec ²	0.00047							
	kg-cm ²	.53							
Brake Current @24 VDC +/- 10%	A	0.5							
Brake Holding Torque - Dry	lbf-in	70							
	(Nm)	8							
Brake Engage/Disengage Time	ms	25/50							
Mechanical Time Constant (tm)	ms	1.7	1.7	1.7	1.4	1.4	1.4	1.4	
Electrical Time Constant (te)	ms	7.9	7.9	8.2	9.9	10.1	9.9	10.1	
Bus Voltage	Vrms	24 VDC	48 VDC	120 VDC	115 VDC	230 VDC	400 VDC	460 VDC	
Speed @ Bus Voltage	RPM	1000	2500	4000	4000	4000	4000	4000	
Stator Insulation Class		Class 180H							
Ambient Temperature Rating		-29°C to 93°C							
CSA/ATEX Temperature Class		T3, 200° C Maximum Allowable Surface Temperature							
Continuous Force Ratings	Stator	2A8-10	2B8-25	2C8-40	218-40	238-40	258-40	268-40	
Ambient Temp	°C	25°/80°	25°/80°	25°/80°	25°/80°	25°/80°	25°/80°	25°/80°	
0.1 inch lead	EL100-0601	lbf	1806/1246	1806/1246	1834/1266	1989/1373	2011/1387	1986/1371	2008/1385
0.1 inch lead	EL100-0601	(N)	8032/5542	8032/5542	8160/5631	8848/6105	8943/6171	8835/6097	8930/6162
0.2 inch lead	EL100-0602	lbf	903/623	903/623	917/633	995/686	1005/694	993/685	1004/693
0.2 inch lead	EL100-0602	(N)	4016/2771	4016/2771	4080/2815	4424/3053	4472/3086	4417/3048	4465/3081
0.5 inch lead	EL100-0605	lbf	361/249	361/249	367/253	398/275	402/277	397/274	402/277
0.5 inch lead	EL100-0605	(N)	1606/1108	1606/1108	1632/1126	1770/1221	1789/1234	1767/1219	1786/1232
For amplifiers using peak sinusoidal ratings, multiply RMS sinusoidal Kt by 0.707, and peak current by 1.414.									
All temperature ratings ambient.									

EL100 Dimensions

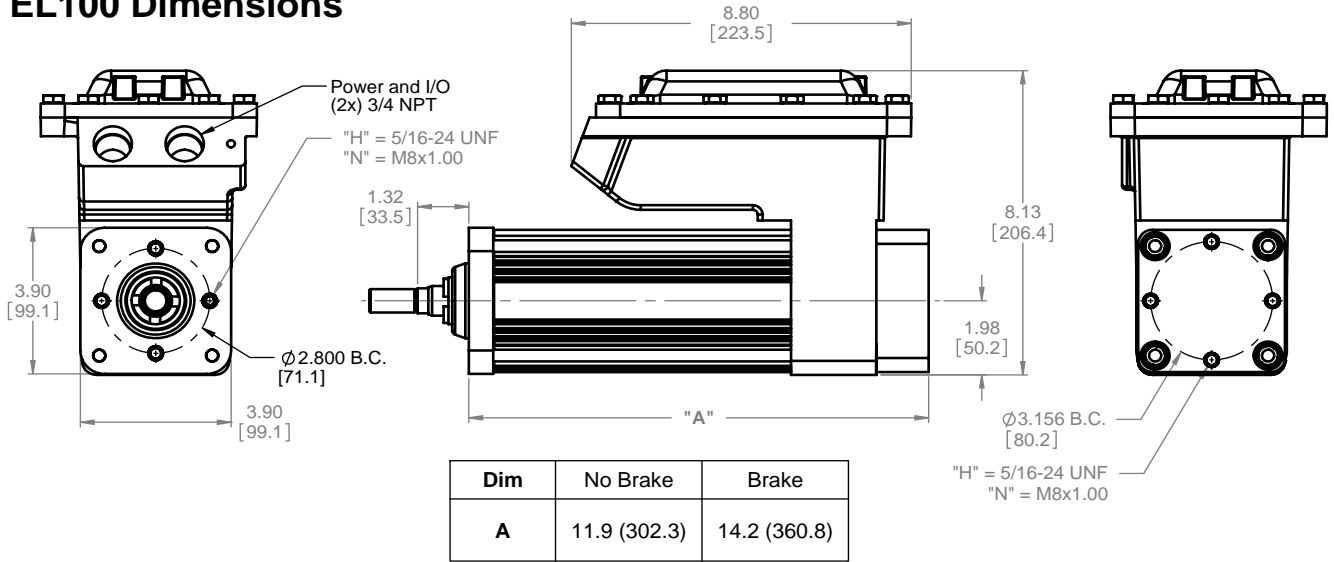

Front Flange or Clevis Mount

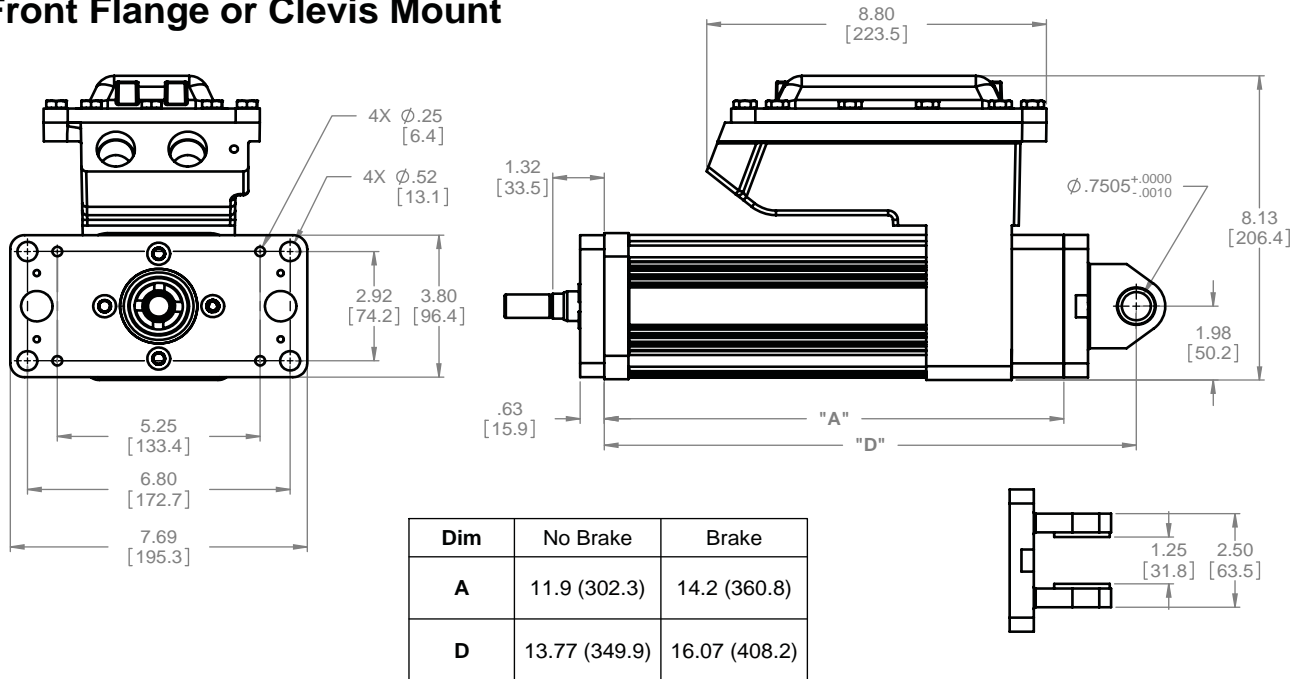

Actuator Rod End Options



A	B (Inch)	B (Metric)	ϕ C	D	ϕ E	F	Male "M" (Inch)	Male "A" (Metric)	Female "F" (Inch)	Female "B" (Metric)
1.250 (31.8)	0.625	17.0	0.787 (20.0)	0.281 (7.1)	0.725 (18.4)	1.000 (25.4)	1/2-20 UNF-2A	M16x1.5 6g	1/2-20 UNF-2B	M16x1.5 6h

Actuator Model Designation

EL100-CCDD-EFG-HHH-IJK-LL-MM-NN-OOOO

CC = Stroke Length

06 = 5.9 in (150 mm)

DD = Roller Screw Lead (Linear Travel per Screw Revolution)

01 = 0.1 in/rev (2.54 mm/rev)

02 = 0.2 in/rev (5.08 mm/rev)

05 = 0.5 in/rev (12.7 mm/rev)

XX = Special Lead

E = Connections

S = Terminal strips with 3/4" NPT port access, single row

F = Mounting

H = Threaded front and rear face, US standard thread

N = Threaded front and rear face, metric thread

B = Front and rear clevis

C = Standard rear clevis

F = Standard front flange

R = Rear flange

X = Special mounting (consult Exlar)

G = Rod End

M = Male, US standard thread

A = Male, metric thread

F = Female, US standard thread

B = Female, metric thread

W = Male, US std thread 440C SS

R = Male metric thread 440C SS

V = Female US std thread 440C SS

L = Female metric thread 440C SS

X = Special rod end (consult Exlar)

HHH = Controller Feedback Option

XX1 = Custom Feedback. Resolver Only. (Consult Exlar)

AB6 = Allen-Bradley/Rockwell - standard resolver

AM3 = Advanced Motion Control - standard resolver

AP1 = API Controls - standard resolver

BD2 = Baldor - standard resolver

BM2 = Baumuller - standard resolver

BR1 = B&R Automation - standard resolver

CT5 = Control Techniques - standard resolver

CO2 = Copely Controls - standard resolver

HHH (Continued)

DT2 = Delta Tau Data Systems - standard resolver

EL1 = Elmo Motion Control - standard resolver

EX4 = Exlar - standard resolver

IF1 = Infranor - standard resolver

IN6 = Indramat/Bosch-Rexroth - standard resolver

JT1 = Jetter Technologies - standard resolver

KM5 = Kollmorgen/Danaher - standard resolver

LZ5 = Lenze/AC Tech - standard resolver

MD1 = Modicon - standard resolver

MG1 = Moog - standard resolver

MN4 = Momentum - standard resolver

MX1 = Metronix - standard resolver

OR1 = Ormec - standard resolver

PC7 = Parker - standard resolver - European only

PC0 = Parker - standard resolver - US only

PS3 = Pacific Scientific - standard resolver

SM2 = Siemens - standard resolver

SW1 = SEW/Eurodrive - standard resolver

WD1 = Whedco/Fanuc - standard resolver

I = Motor Stacks

2 = 2 stack motor

J = Rated Voltage

A = 24 VDC

B = 48 VDC

C = 120 VDC

1 = 115 Volt RMS

3 = 230 Volt RMS

5 = 400 Volt RMS

6 = 460 Volt RMS

X = Special voltage rating - not to exceed 460 Volt RMS

K = Motor Poles

8 = 8 Pole Motor

LL = Rated Motor Speed at Rated Voltage

01 - 99 = Two digit number x 100 = rated RPM

MM = Mechanical Option (Multiple options may apply - separated by "-")

XL = Special lubrication, Mobilgrease 28 or other (please specify)

PF = Pre-loaded roller screw follower

AR = External anti-rotate assembly (requires flange mount option)

RB = Rear brake

XT = Special housing option (see options below)

Hard anodized aluminum motor housing parts

Epoxy coated terminal housing (casting)

NN = Haz Loc Temp Rating

T3 = 200 °C maximum allowable surface temperature

OOOOO = Part Number

5 digit numeric part number unique to model configuration

EL100 Terminal Box Wiring Diagram

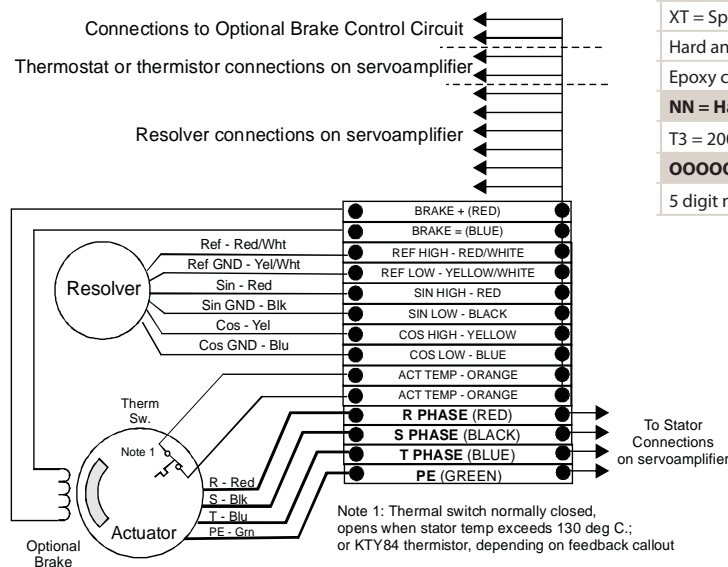

EXLAR

Exlar Corporation
1470 Lake Drive West
Chanhassen, MN 55317
www.exlar.com
Tel: 952-368-3434
Fax: 952-368-4877
PN 44932